

DIVINE GROUP OF COMPANIES

COMPANY PROFILE

CONTENTS

- Company Overview
- Business Strategy for next 5-Years
- Manufacturing Plants
- Activities and available facilities
- Infrastructure
- Design & Development softwares'
- List of machinery at A-44, Sinnar
- Machinery Photographs
- List of machinery at L-21, Ambad
- Machinery Photographs
- Measuring Equipments
- Equipments in Standard room
- Products
- Previous Products (Export)
- Products Manufactured at SMP
- Recognitions
- Our Customers

COMPANY OVERVIEW

- SMP, Sinnar Started its operation in the year 2003.
- Founder & Chairman - **Mr. Shrikant V Padhye**
- Managing Director - **Mr. Ajinkya S Padhye**
- Number Of Directors - 3
- Number of Employees - 150
- Number of Plants – 4
- Specialized in manufacturing of complex sheet metal parts, CNC high precision turned and machined components and Plastic molded parts.
- Supplying to companies from automotive, electrical and pump sector.
- IATF 16949:2016 certified company.

MANUFACTURING PLANTS

I. SMP ENGINEERS & ELECTRICALS PVT. LTD.

- A-44, M.I.D.C., Malegaon Area, Sinnar, Nasik - 422 103. (Main Plant)
- L-21, M.I.D.C., Ambad, Nasik - 422 010.
- H-162, M.I.D.C., Ambad, Nasik – 422010
- Rayakottai Road, opp. LUK India Ltd., Hosur, Tamil Nadu.

Contact Details

Phone : +91 2551 - 230794 , 230463

Fax : +91 2551 230435

Mail : info@divineindia.co.in



II. DIVINE PRECISION COMPONENTS PVT. LTD.

- C-11, M.I.D.C., Malegaon Area, Sinnar Nasik - 422 103.

Contact Details

Phone : +91 2551 - 230895 , 230896

Fax : +91 2551 230895

Mail : dvn_industries@yahoo.com



ACTIVITIES AND AVAILABLE FACILITIES

I. SMP ENGINEERS & ELECTRICALS PVT. LTD.

Manufacturing of –

- i. Sheet Metal Components
- ii. Plastic Injection Moulded Components
- iii. Fabricated & Riveted Assemblies

II. DIVINE PRECISION COMPONENTS PVT. LTD.

Manufacturing of –

- i. CNC precision turned and machined components
- ii. Press Tools, Plastic Injection Moulds, Jigs & Fixtures

DESIGN & DEVELOPMENT :

- i. VISI CAD & CAM
- ii. DYNA FORM - FEA software for sheet metal
- iii. DELCAM - CAM software



INFRASTRUCTURE



Main Plant Building, A-44, M.I.D.C. Sinnar



Conference Hall at A-44, M.I.D.C. Sinnar



Office at C-11, M.I.D.C. Sinnar



Office Building at L-21, M.I.D.C. Ambad

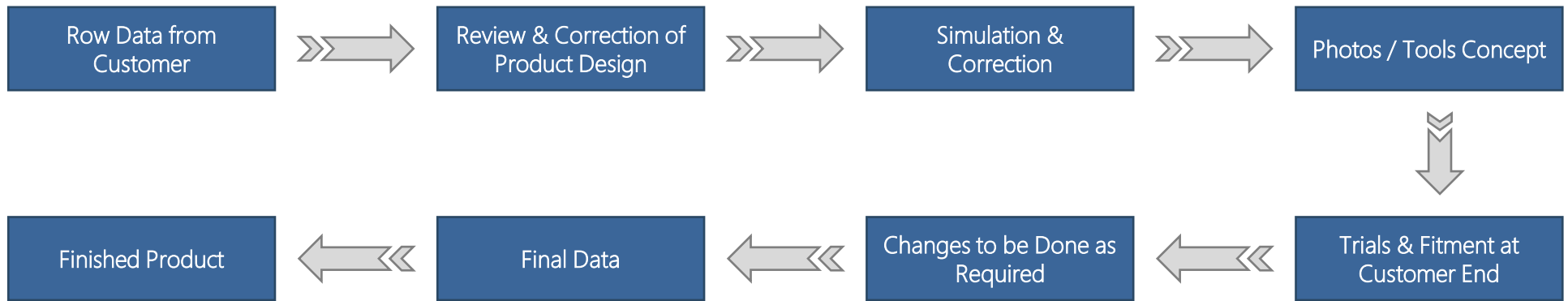

- **The development team at SMP constantly thrives to add value to its products.**
- **At SMP, we use the latest software for design and development of tooling and its parts.**
- Software such as VISI CAD, CATIA and 3-D Analysis software such as LS-Dyna.

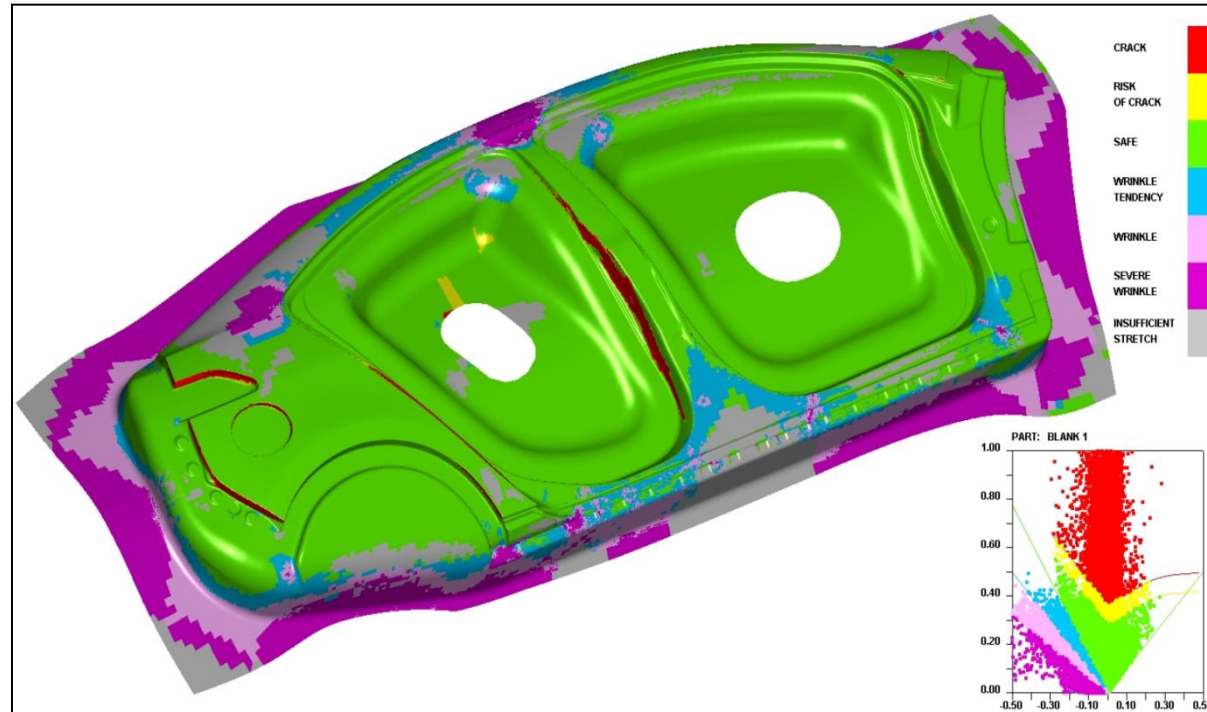
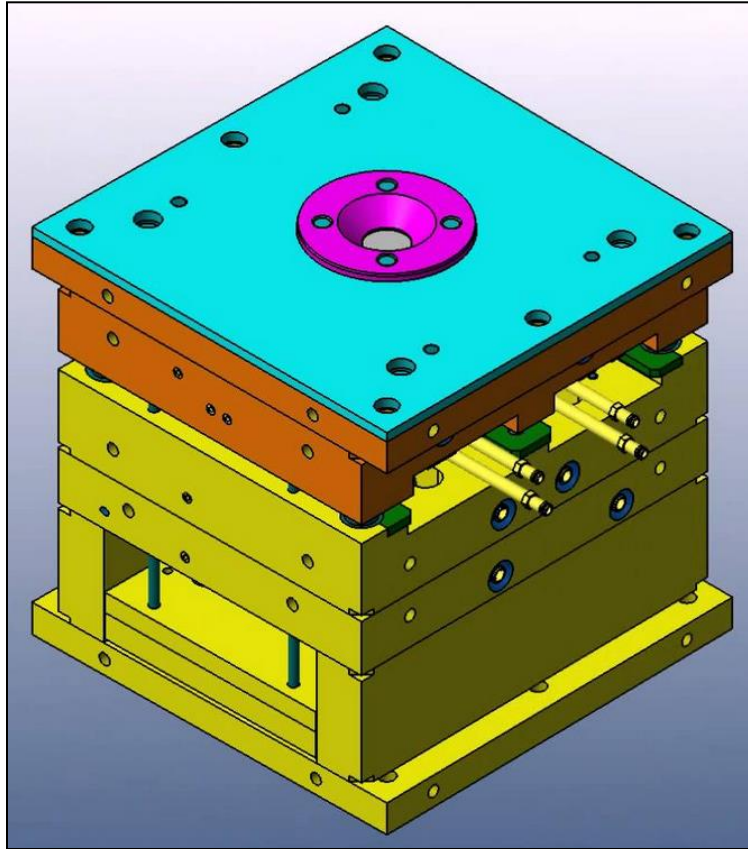

DESIGN SOFTWARES :

- i. VISI CAD & CAM
- ii. DYNA FORM - FEA software for sheet metal
- iii. DELCAM - CAM software

DESIGN & DEVELOPMENT SOFTWARES'

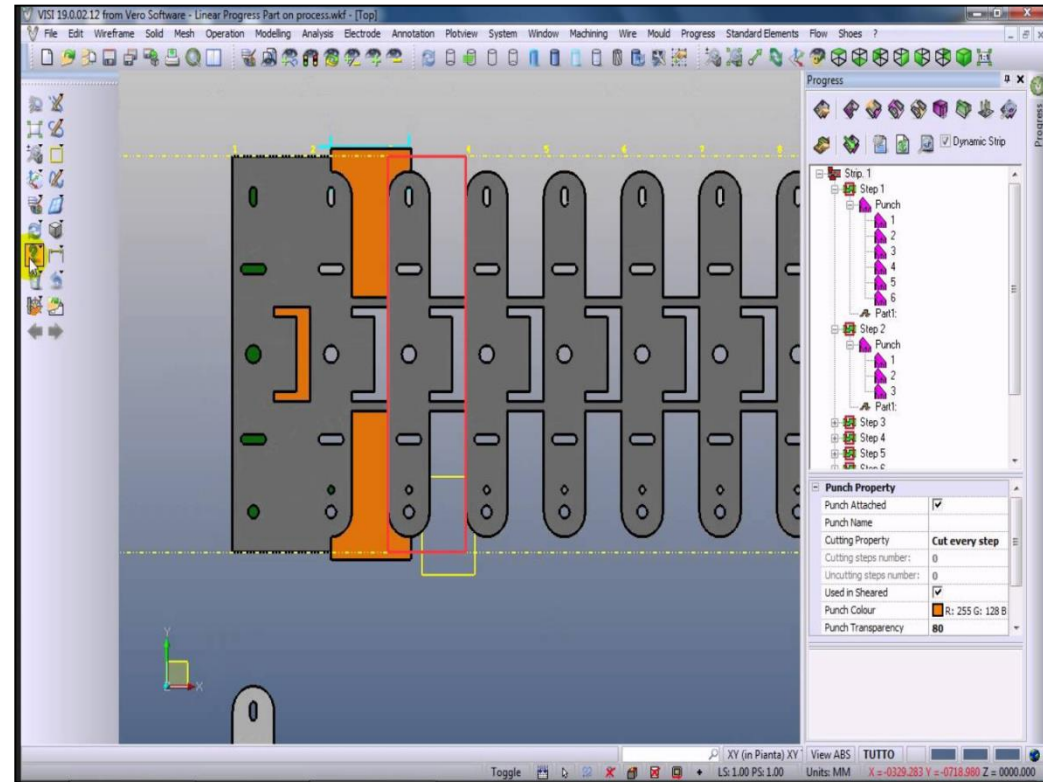
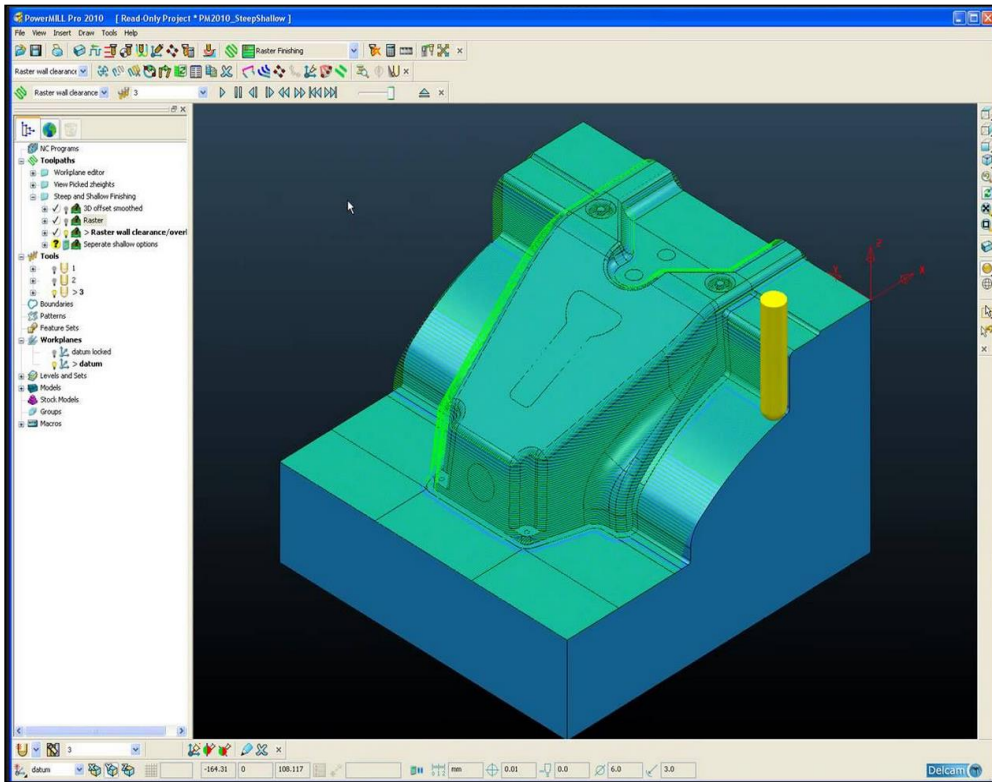

DESIGN SOFTWARES :

- i. VISI CAD, CATIA
- ii. DYNA FORM - FEA software for sheet metal
- iii. DELCAM - CAM software

MACHINERY

- YSD make Hydraulic guillotine shearing machine.
- In-house tool maintenance facility with tool room machines like CNC lathe, DRO milling, surface grinder, cylindrical grinder etc.
- For development purpose, we have in-house VMC machines with 3 axis and 4 axis.
- Combination of SEW and Indian make pneumatic and mechanical press machines ranging from 20T to 200T.
- 80T and 50T Hydraulic press machine for deep draw press components.
- We also have a dedicated machining shop which has Japanese make CNC turning centers.
- In-house welding shop having CO2 welding, capacitor discharge, Spot welding, projection welding machines.



Press shop at Sinnar Plant

MACHINERY



2 Double Action Hydraulic Press

(80T + 40T) Draws up to 500 mm length;

50T Double Action press with higher speed



SEW make Press machines at Sinnar

MACHINERY



Plastic Injection Molding Shop at Sinnar Plant

MACHINERY



Mould Storage



Ultrasonic Welding Machines

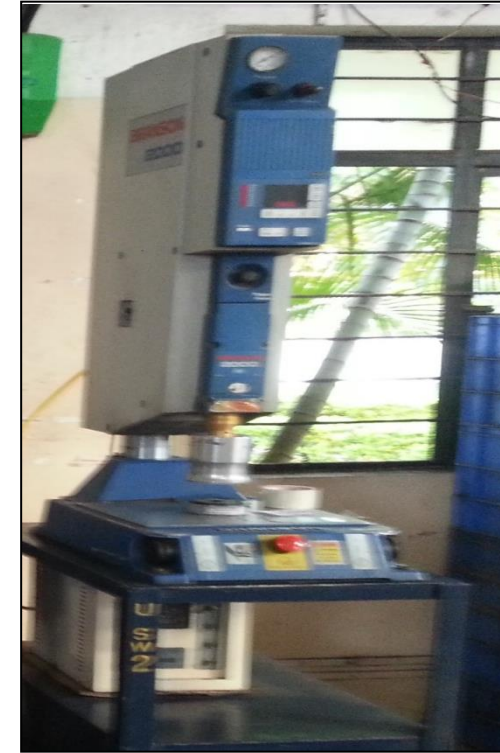

MACHINERY



In-house Tool Maintenance facility



Tool Storage at A-44, M.I.D.C. Sinnar



Assembly Shop at A-44, M.I.D.C. Sinnar

MACHINERY



CNC Machine Shop at L-21, M.I.D.C. Ambad

MEASURING EQUIPMENTS

Sr. No.	Name Of the Machine	Manufacturer	Size
1	CNC CMM	Fero, Italy	Dia. 200 x 150 X 150
2	Profile Projector	Mitutoyo	10 X, 20 X, 50 X lenses
3	Height Master	Electronica	650 mm height
4	Surface Roughness Tester	Mitutoyo	
5	Hardness Tester	Saroj	
6	Plating thickness tester		
7	Vernier, Micrometer, Height Gauges, Dial Gauges etc.	Insize, Mitutoyo, Baker	
8	Bore Gauges		
9	Plug, Ring Gauges, Checking Fixtures etc.		
10	Torque Wrenches		
11	Air Gauges		
12	Digital Comparators		
13	Crack Detection Equipment	Technoflux	

EQUIPMENTS IN STANDARD ROOM



CNC CMM (Co-ordinate Measuring Machine)



Profile Projector



Height Master

EQUIPMENTS IN STANDARD ROOM



Height Gauge



Air Gauges



Crack Detector



Suspension Parts Manufactured by SMP

COMPONENTS



Other Spring Seats manufactured by SMP
Customer – Magneti Marelli Shock Absorbers India Ltd.

COMPONENTS



4- Wheeler Suspension Parts
Customer – Gabriel India Ltd.



4-Wheeler Knuckle Bracket Assembly

Customer – Gabriel India Ltd.

COMPONENTS

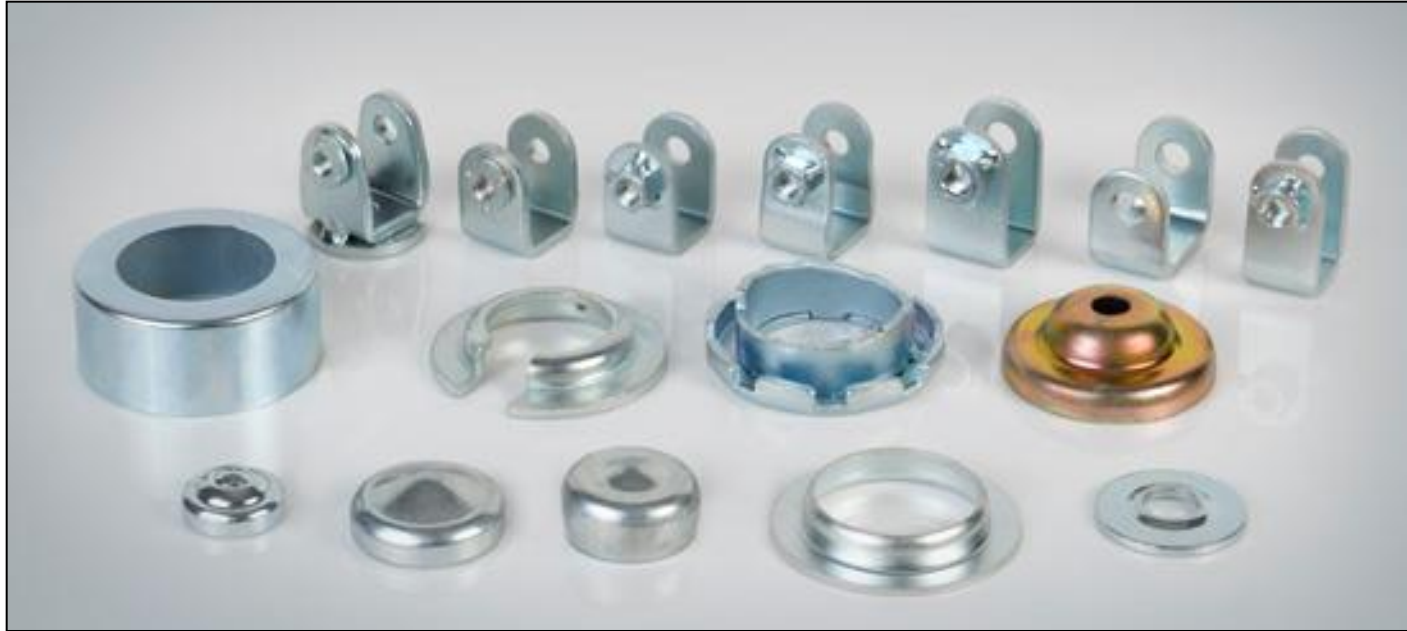

2-wheeler and 4-wheeler Suspension parts

COMPONENTS

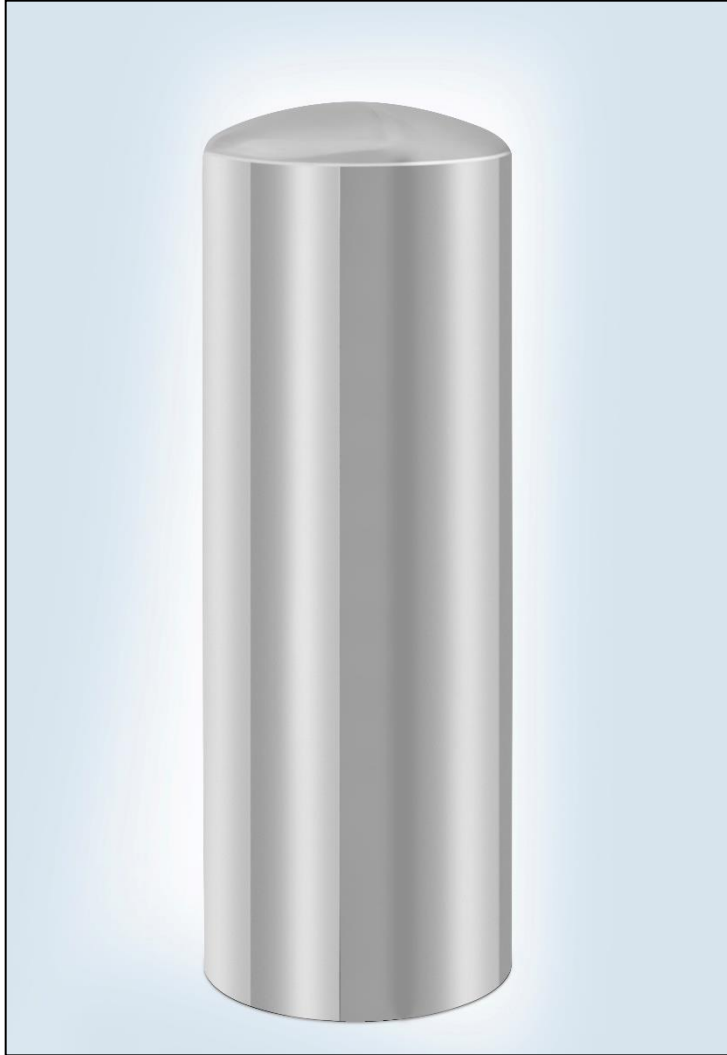

Filter Shell Bowl

Customer - Fleetguard Filters



Bump Stopper Assembly

Customer – Gabriel India Ltd.

COMPONENTS



Front / Rear Endplate RM
Customer – Tenneco, Pune



Baffle
Customer – Tenneco, Pune

COMPONENTS



Endplate Inlet / Outlet
Customer – Tenneco, Pune



U-Tube
Customer – Tenneco, Pune

COMPONENTS



Wiper Motor House
Customer - PMP Auto



Wiper Mechanism parts
Customer - PMP Auto

COMPONENTS



High Precision machined Shafts
Customer – Concentric Pumps, UK



Precision Machined Parts

COMPONENTS



Dust Cover and Spring Cup
Customer – Gabriel India Ltd.



Container Door Hinge
Customer – Citizen, Dubai

COMPONENTS



Motor Cover

Customer – Danaher Corporation, USA



Pump Impellers

Customers – KSB Pumps & Concentric Pumps



Plastic Injection Molding Parts

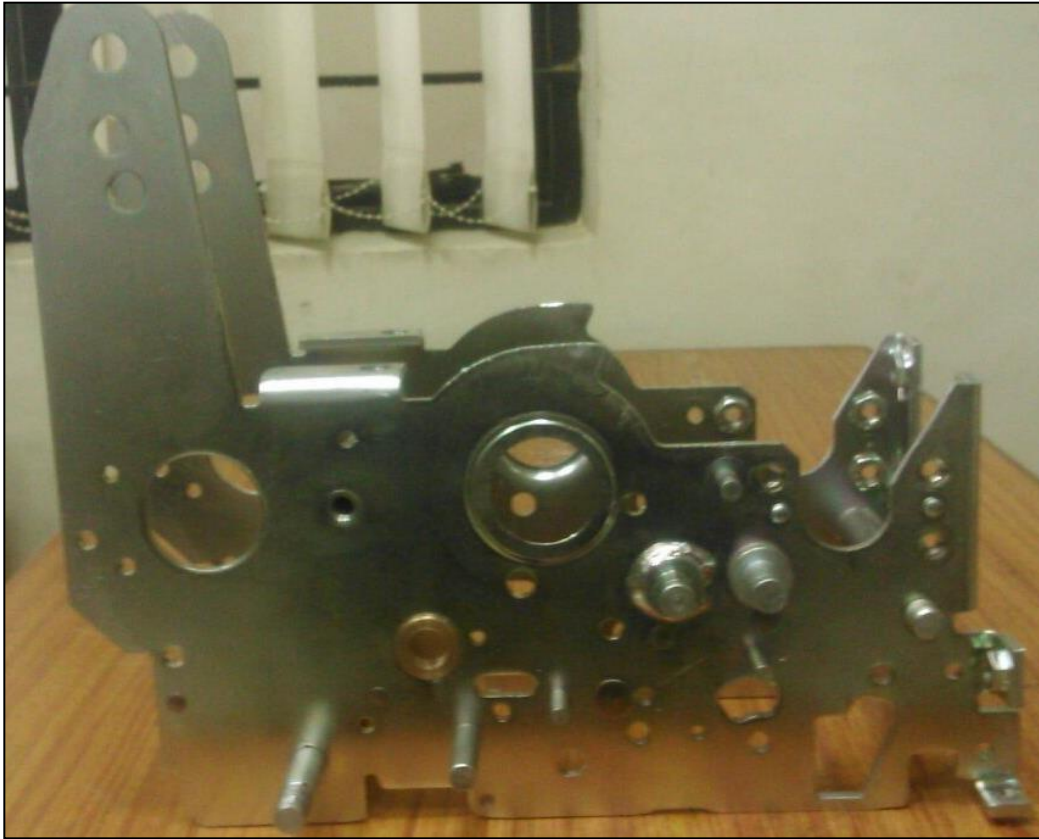

EL Mechanism components
Customer – ABB India Ltd.

COMPONENTS

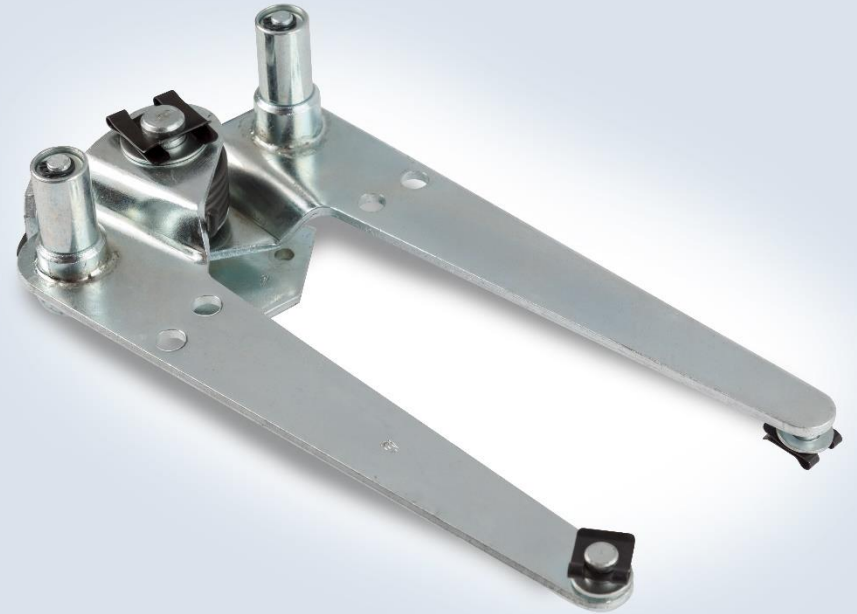

COMPONENTS



Crompton Greaves parts developed & manufactured by SMP

COMPONENTS



RHOM (Rotary Handle Operating Mechanism) Assembly



Export Components

PREVIOUS PRODUCTS (EXPORT)



Schneider Electric Global



Kavlico - USA



Crompton Greaves



Mafelec - France



Awards & Recognitions

- 2009-10 : SMP Engineers & Electricals Pvt. Ltd. is a VINCOTTE ISO / TS 16949 certified company.
- President's award for best supplier of Gabriel India Ltd. in 2012-13.
- 2011-12 Supplier Awards from -
 - i. Concentric Pumps India Ltd.
 - ii. ABB India Ltd. (Nashik)
- VSME implementation award 2016-17 from Gabriel India Ltd.
- 2017-18 : TLC Award for implementation of WCM practices.
- 2017-18 : SMP Engineers & Electricals Pvt. Ltd. is a IATF 16949:2016 certified company.
- 2017-18 : SMP receives two awards from Gabriel India Ltd. for –
 - Zero Defect
 - Best In Support Role Award 'Critical Business Scenario'

OUR CUSTOMERS

GABRIEL
Gabriel India Limited

TENNECO

pricol

**MAGNETI
MARELLI**

**ARIB
ARIB**

Schneider
Electric

TOSHIBA
Leading Innovation >>>

**Crompton
Greaves**

ENDURANCE

Fleetguard

CONCENTRIC

KSB

Taj Al Mulook
a chemical distribuon company

HYOSUNG

DANAHER

L&T Switchgear

MAHLE